

Measuring and testing equipment

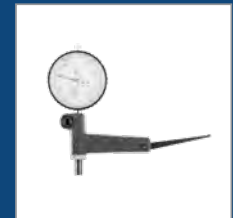

Run-out testers

Taper measuring instrument

Comparator stands

Indicator stands

Measuring bridges for depth gauges

Interior sensing lever

Angle sensing lever

Small measuring devices



Qualitätsmanagementsystem
ISO 9001

- Kundenorientierung
- Kundenzufriedenheit
- Fortlaufende Verbesserung
- System- bzw. Prozesswirksamkeit

ID 15 100 21396

www.tuev-thueringen.de

	Seite
Tolerances	3
Run-out testers	4-20
Dial gauges and collets	19
Straightening fixture for hand lever press	21
KMG Taper measuring instrument	22-23
Comparator stands	24-33
Indicator stands	34-37
Small measuring devices	38-39

BENZING PRODUCTS AND SERVICES:

Consultancy

Take advantage of our many years of experience in the design and production of measuring instruments. We can help solve your measurement problems. We'll be glad to help you devise and implement solutions.

Inspection reports

On request, we can prepare inspection reports on a 3D measuring machine with traceable measurement results.

Sale of separate components

All of the components and assemblies in the measuring devices shown in the catalogue can be ordered separately.

Quality assurance

The quality of our products is ensured by a certified quality assurance system based on DIN EN ISO 9001:2015.

BENZING SERVICE:

Grinding and lapping

The surfaces of measuring table plates wear down with frequent use. The surfaces can be reworked to make them flat again. Our grinding and lapping service will restore your measuring table plate (even if made by another company) to as-new condition.

Care instructions

Benzing measuring devices have a much longer service life when they are treated with care. This is why you should protect uncoated metal surfaces with a professional rust inhibitor.

Flatness of measuring table plates – work-holding tables

All of the measuring table plates listed are lapped. Plates designated as “ground” are precision-ground.

Model	Measuring table dimensions mm	Material	Precision as per DIN 876	Tolerance μm
MT 25	dia. 25	Steel	0	4.10
MT 50	dia. 50	Steel	0	4.20
MT 50 K	dia. 50.	Ceramic	Factory standard	2.00
MT 100	60 x 70	Steel	0	4.28
MT 100 ground	60 x 70	Steel	Factory standard	7.00
MT 100 bK	65 x 75	Ceramic	Factory standard	2.15
MT 100 K	65 x 75	Ceramic	Factory standard	2.15
MT 130	98 x 115	Steel	0	4.46
MT 130 bK	98 x 115	Ceramic	00	2.23
MT 130 K	98 x 115	Ceramic	00	2.23
MT 150 U-1	dia. 115	Steel	0	4.46
MT 150 U-2	98 x 115	Steel	0	4.46
MT 150 U-3	48 x 100	Steel	0	4.40
MT 160	170 x 215	Steel	0	4.86
MT 160 ground	170 x 215	Steel	Factory standard	16.0
MT 170	150 x 260	Granite	00	2.52
MT 171	150 x 260	Granite	00	2.52
MT 172	150 x 260	Granite	00	2.52
MT 180	98 x 180	Steel	0	4.72
MT 180 ground	98 x 180	Steel	Factory standard	10.0
MT 300	300 x 350	Granite	00	2.70
RP 50-200	AT 350	Cast iron	1	13.50
RP 50-350	AT 500	Cast iron	1	15.00
RP 75-200	AT 350	Cast iron	1	13.50
RP 75-350	AT 500	Cast iron	1	15.00
RP 100-450	AT 700	Cast iron	1	17.00
RP 150-450	AT 700	Cast iron	1	17.00
RP 200-650	AT 1100	Granite	0	8.40

Run-out testers

Height of centres 50 mm

height of centres 75 mm

Benzing run-out testers consist of a base plate, a pair of tailstocks with centres (60°) on the T-slot guide, and a dial gauge stand on the T-slot clamp.

The centre of the right tailstock can be pulled back using a lever. This permits easy insertion and removal of the test specimen. The centre returns to its position by spring force.

The standard centres of the tailstocks can be replaced by hollow centres, V-block inserts or carbide centres.

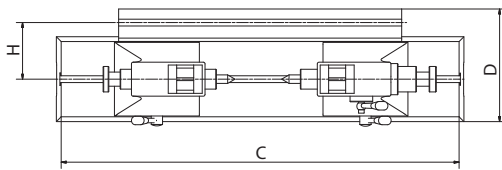
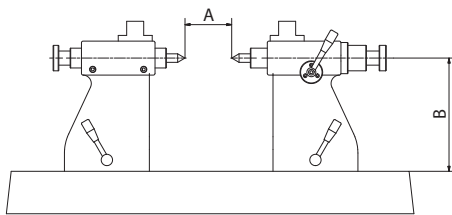
RP 50-200

RP 75-350P

Model			RP 50-200	RP 50-350	RP 75-200 P	RP 75-350 P
maximum centre distance	A	mm	200	350	200	350
Height of centres	B	mm	50	50	75	75
Dimensions of base plate	CxD	mm	350 x 110	500 x 110	350 x 110	500 x 110
Flatness of base plate			DIN 876/1	DIN 876/1	DIN 876/1	DIN 876/1
T-slot width		mm	10H7	10H7	10H7	10H7
Contact area in V-block		mm			5 - 20	5 - 20
Dial gauge holder		mm	8H7	8H7	8H7	8H7
Travel of movable centre		mm	8	8	8	8
Distance guide/clamping slot	H	mm	58	58	58	58
Height with stand		mm	260	260	260	260
Weight		kg	ca. 8	ca. 11	ca. 9	ca. 12

Accessories for run-out testers with height of centres 50 mm height of centres 75 mm

V-block inserts PE 004-52

For checking non-centred parts and long parts. V-block inserts are put into the tailstocks instead of centres.



Centering points – hollow centres 004-56 with centering hole DIN 332-A1.6 x 3.8

Centering points 004-57

60° carbide tipped
Shank of centering points: dia. 16 mm



Centering points 004-56S

Standard centering points, 60°

We will be glad to manufacture centering points according to your specifications.



Tailstock pairs



RST 50

Spring tension of the right tailstock

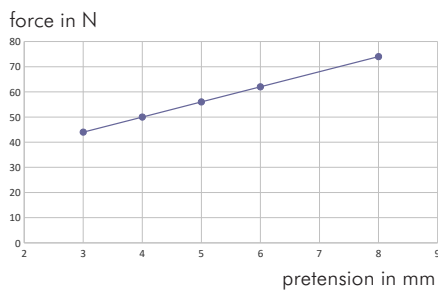

RST 75 P

Model		RST 50	RST 75 P
Height of centres	mm	50	75
Width of T-slot block	mm	10h6	10h6
Contact area in V-block	mm		5 - 20
Surface LxW	mm	66 x 55	66 x 55
Travel distance of movable centre	mm	8	8
Accuracy centres height		±0.01	±0.01
Weight/pair	kg	ca. 2.5	ca. 3.5

Vertically adjustable Roller blocks or V-blocks

To compensate for different diameters of the test specimen, a gauge block with thickness h can be placed under the vertically adjustable support on the left. The thickness h of the gauge block is calculated as follows:

$$h = h_1 - h_2$$

V-blocks:

$$h_1 = d_1 / \sqrt{2}$$

$$h_2 = d_2 / \sqrt{2}$$

Roller blocks

$$h_1 = \sqrt{(13 + \frac{d_1}{2})^2 - 175.5625}$$

$$h_2 = \sqrt{13 + (\frac{d_2}{2})^2 - 175.5625}$$

$h = \text{max. } 23\text{mm}$

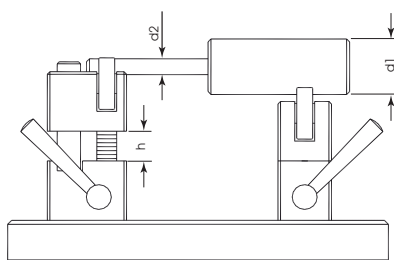

with vertical adjustment

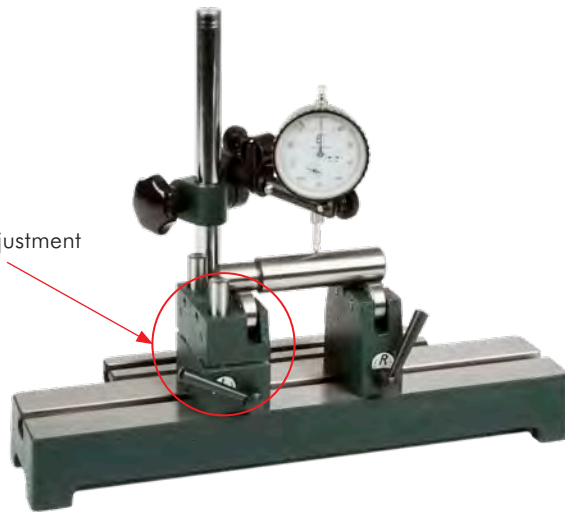

V-blocks and Roller blocks are always supplied in pairs.



		V-blocks	V-blocks	Roller blocks	Roller blocks
Model		PB 004-53	PB 004-63HV	AB 004-54	AB 004-64
Vertically adjustable			•		•
Contact area in V-block	mm	dia. = 5 - 25	dia. = 5 - 25	dia. = 2 - 40	dia. = 2 - 32
V-block angle		90°	90°		
V-block width	mm	10	10		
Wheel width	mm			8	8
Height of centres at d = 10 mm	mm			56	66
Height of centres at d = 20 mm	mm	65	74		
Minimum spacing	mm	20	14	22	16
Travel distance	mm		25		25
Width of T-slot block	mm	10h6	10h6	10h6	10h6
Run-out accuracy	mm			0.003	0.003
Weight	kg/pair	ca. 1.0	ca. 1.8	ca. 1.0	ca. 1.8

End stop and dial gauge holder for V-blocks and roller blocks



End stop		AS 004-53
Diameter	mm	8
Dial gauge holder		MU 004-53
Mounting hole	mm	8H7

The end stop can be used to hold the test specimen in an axial position.

Pressure wheel AR 004-51



Pressure wheel for holding and turning the test specimen with constant force in V-blocks or roller blocks. The pressure wheel is mounted in the T-slot clamp.

Dial gauges are not included.

Accessories for run-out testers with height of centres 50 mm height of centres 75 mm

Additional dial gauge stands can be used to set up further measuring points on run-out testers. The dial gauge stands have a universal swivel head. They are available with or without fine adjustment.

Model		MS 004-55	MS 004-55 S
Height	mm	220	220
Column dia.	mm	16	16
Measuring range	mm	180	180
Dial gauge holder	mm	8H7	8H7
Fine adjustment		•	
Weight	kg	ca. 0.9	ca. 0.9



MS 004-55



MS 004-55 S

Model		THL-50
Height of centres fixed	mm	50
Dial gauge holder	mm	8H7
for T-slot	mm	10H7

This comparator holder allows the dial gauge to be locked in a horizontal position and adapted to the test specimen by means of an extension.

Comparator holder



Run-out testers

Height of centres 100 mm

Height of centres 150 mm

Benzing run-out testers consist of a base plate, a pair of tailstocks with centres (60°) on the T-slot guide, and a dial gauge stand on the T-slot clamp.

The centre of the right tailstock can be pulled back using a lever. This permits easy insertion and removal of the test specimen. The centre returns to its position by spring force.

The standard centres of the tailstocks can be replaced by hollow centres, V-block inserts or carbide centres.

The tailstocks of these models are also available with V-blocks mounted on the top (P version).



Picture without top-mounted V-blocks

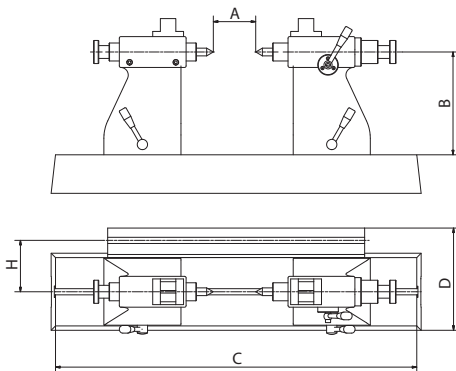

Spring tension of the right tailstock

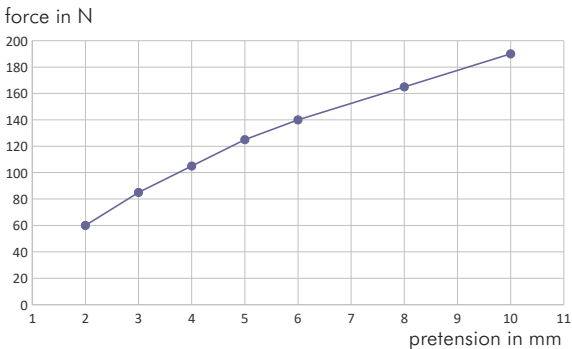

Picture without top-mounted V-blocks

Model			RP 100-450	RP 100-450 P*	RP 150-450	RP 150-450 P*
maximum centre distance	A	mm	450	450	450	450
Height of centres	B	mm	100	100	150	150
Dimensions of base plate	CxD	mm	720 x 180	720 x 180	720 x 180	720 x 180
Flatness of base plate			DIN 876/1	DIN 876/1	DIN 876/1	DIN 876/1
Degree of accuracy			1	1	1	1
T-slot width		mm	12H7	12H7	12H7	12H7
Contact area in V-block		mm		8 - 32		8 - 32
Dial gauge holder		mm	8H7	8H7	8H7	8H7
Travel of movable centre		mm	8	8	8	8
Distance guide/clamping slot	H	mm	100	100	100	100
Height with stand		mm	320	320	520	520
Weight		kg	35	35	38	38

*P = with V-block

Dial gauges are not included.

Accessories for run-out testers with
height of centres 100 mm
height of centres 150 mm



V-block inserts PE 002-102

For checking non-centred parts and long parts.
V-block inserts are put into the tailstocks instead of centres.

Model		PE 002-102
Contact area in V-block	mm	d = 8 - 45
V-block angle		90 °
Height of centres at d = 10 mm	mm	130
Weight	kg/pair	ca. 1.0

Centering points – hollow centres 002-106

with centering hole DIN 332-A 1.6 x 3.8

Centering points 002-107

60° carbide tipped
Shank of centering points: dia. 22 mm

Centering points 002-106S

Standard centering points, 60°

Live centering points 002-106 M

60°, dia. max = 15 mm
Centre distances reduced by 90 mm

Our RST 100 and RST 150 tailstocks can also be supplied with an MK2 holder.

Tailstock pairs

We will be glad to manufacture centering points according to your specifications.



RST 100



RST 100 P

Model		RST 100	RST 100 P*	RST 150	RST 150 P*
Height of centres	mm	100	100	150	150
Width of T-slot block	mm	12h6	12h6	12h6	12h6
Contact area in V-block	mm		8 - 32		8 - 32
Surface LxW	mm	85 x 80	85 x 80	95 x 85	95 x 85
Travel of movable centre	mm	8	8	8	8
Accuracy centres height	mm	±0.01	±0.01	±0.01	±0.01
Weight/pair	kg	ca. 9	ca. 9	ca. 12	ca. 12

*P = with V-block

Tailstocks with center point movement either by hand wheel or pneumatic cylinder

In the models with a pneumatic cylinder the forward and return speed of the center point can be set using speed regulation valves, which are fitted as standard.



RST 100 RH
RST 150 RH



RST 100 RP
RST 150 RP

Model		RST 100 RH	RST 100 RP	RST 150 RH	RST 150 RP
Height of centres	mm	100	100	150	150
Width of T-slot block	mm	12h6	12h6	12h6	12h6
Surface LxW	mm	85 x 80	85 x 80	95 x 85	95 x 85
Travel of movable centre	mm	20	20	20	20
Accuracy centres height	mm	±0.01	±0.01	±0.01	±0.01
Hand wheel		•		•	
Pneumatic cylinder			•		•
Weight/pair	kg	ca. 9	ca. 9	ca. 12	ca. 12

RH = with hand wheel RP = with pneumatic cylinder

Vertically adjustable Roller blocks or V-blocks

To compensate for different diameters of the test specimen, a gauge block with thickness h can be placed under the vertically adjustable support on the left. The thickness h is calculated as follows:

$$h = h_1 - h_2$$

V-blocks:

$$h_1 = d_1 / \sqrt{2}$$

$$h_2 = d_2 / \sqrt{2}$$

Roller blocks

$$h_1 = \sqrt{(17.5 + \frac{d_1}{2})^2 - 324}$$

$$h_2 = \sqrt{(17.5 + \frac{d_2}{2})^2 - 324}$$

$$h = \text{max. } 42 \text{ mm}$$

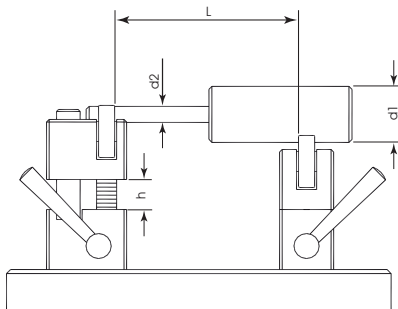

with vertical adjustment

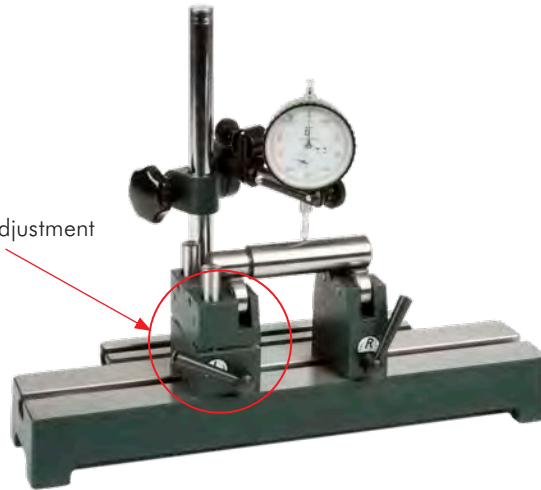

		V-blocks	V-blocks	Roller blocks	Roller blocks
Model		PB 002-103	PB 002-113HV	AB 002-104	AB 002-114HV
Vertically adjustable			•		•
Contact area in V-block	mm	dia. = 8 - 50	dia. = 8 - 50	dia. = 2 - 60	dia. = 2 - 65
V-block angle		90°	90°		
V-block width	mm	10	10		
Wheel width	mm			8	8
Height of centres at d = 10 mm	mm	93	102	91.5	99
Minimum spacing	mm	30	18	32	22
Travel distance			50		50
Width of T-slot block	mm	12h6	12h6	12h6	12h6
Run-out accuracy				0.003	0.003
Weight	kg/pair	ca. 4.0	ca. 5.7	ca. 4.0	ca. 5.7

End stop and dial gauge holder for V-blocks and roller blocks



End stop		AS 002-103
Diameter	mm	8
Dial gauge holder		MU 002-103
Mounting hole	mm	8H7

The end stop can be used to hold the test specimen in an axial position.

V-blocks and Roller blocks are always supplied in pairs.



Comparator holder

Model		THL-100
Height of centres fixed	mm	100
Dial gauge holder	mm	8H7
for T-Slot	mm	12H7

This comparator holder allows the dial gauge to be locked in a horizontal position and adapted to the test specimen by means of an extension.

Dial gauges are not included.

Accessories for run-out testers with height of centres 100 mm height of centres 150 mm



The tailstock with rotating collet attachment is used in place of the left tailstock with fixed centre.

Type F 14 and F 20 collets can be used, depending on the model. Collets are not included.

The tolerance of the collet must be added to the stated run-out accuracy of the tailstock. See the table on page 19 for details.

Delivery comes without work-holding table.



Matching collets can be found on page 19.

Model		RST 100 D	RST 100D-16	RST 150 D
Height of centres	mm	100	100	150
Width of T-slot block	mm	12h6	12h6	12h6
Surface LxW	mm	85 x 80	85 x 80	95 x 85
Collet type	mm	F14	F20	F14
for collet range	mm	1 - 10	1 - 16	1 - 10
Run-out accuracy without collet	mm	0.005	0.005	0.005
Weight	kg	ca. 4	ca. 4	ca. 5

Dial gauge stand



Additional dial gauge stands can be used to set up further measuring points on run-out testers. The dial gauge stands have a universal swivel head and a fine adjustment.

Modell		MS 002-105	MS 002-105-450
Height	mm	240	440
Measuring range – vertical	mm	230	430
Reach	mm	130	130
Column dia.	mm	22	22
Dial gauge holder		8h7	8h7
Fine adjustment		•	•
Weight	kg	1.5	2.0

Run-out testers with a granite base plate Height of centres 200 mm

The work-holding table of the run-out tester is made of dark granite that is free of defects. Flatness as per DIN 876/1. A dull chrome-plated T-slot is recessed into the granite. The granite base plate is mounted on three vertically adjustable feet with ball bearing inserts.

Tailstocks are made of high-quality cast iron mounted on bearings. The contact surfaces are precision-ground. The centre of the right tailstock can be pulled back with a lever. This permits easy insertion and removal of the test specimen. The centre returns to its position by spring force.

The standard centres of the tailstocks can be replaced by special centres.

Dial gauge stands are mounted on the T-slot guide.

RP 200-650P



The picture shows the run-out tester with tailstock pair RST 200 P. The basic version RP 200-650 comes without top-mounted V-blocks.

MS 200

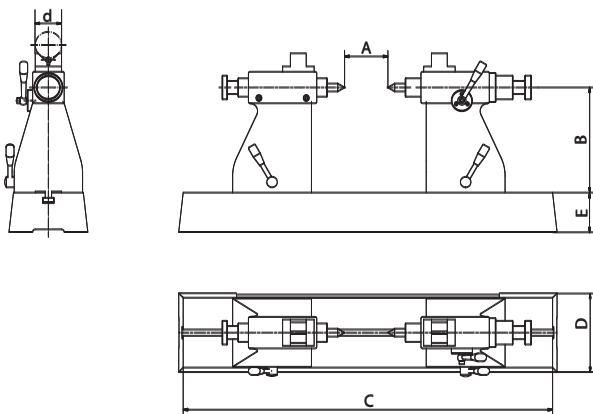

Modell	MS 200	
Total height	mm	420
Measuring range - vertical	mm	365
Measuring range - horizontal	mm	180
Column diam:	mm	35
Dial gauge holder	mm	8H7
Interchangeable dial gauge holder		•
Horizontal arm with rotation lock		opt.
Weight	kg	7.0

Model			RP 200-650	RP 200-650P
maximum centre distance	A	mm	650	650
Height of centres	B	mm	200*	200*
Dimensions of granite base plate	CxD xE	mm	1100 x 180 x 140*	1100 x 180 x 140*
Flatness of base plate			DIN 876/0*	DIN 876/0*
Degree of accuracy			0	0
T-slot width		mm	14H7	14H7
Straightness of T-slot guide		µm/m	10	10
Surface of tailstock		mm	130 x 150	130 x 150
Sleeve holder			MK 2	MK 2
Contact area in V-block		mm		d = 10 - 50
Dial gauge holder		mm	8H7	8H7
Travel of movable centre		mm	20	20
Height with stand		mm	650	650
Weight		kg	ca. 115	ca. 116

* Other dimensions and accuracies can be supplied at short notice.

Accessories for run-out testers with height of centres 200 mm

Tailstock pair RST 200P

Top-mounted V-blocks allow testing of non-centred or long parts.

RST 200P



Tailstock pair RST 200RH

The sleeve of the left tailstock is fixed, and the right sleeve is moved back and forth using the hand wheel.

RST 200RH

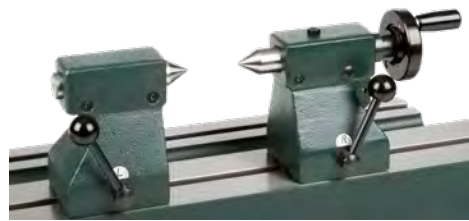

Tailstock pair RST 200RP

The right sleeve is moved back and forth using a double-acting pneumatic cylinder. The forward and return speed of the sleeve can be set using speed regulation valves, which are fitted as standard.

RST 200RP



Roller blocks AB 200

Instead of tailstocks roller blocks can be fixed on the base plate.

AB 200



Model		RST 200P	RST 200RH	RST 200RP	AB 200
Height of centres at diam. 25 mm	mm	200	200	200	147
Roller width	mm				15
Load / pair	kg	40	40	40	150
Width of T-slot block	mm	14h6	14h6	14h6	14h6
Surface LxW	mm	130 x 150	130 x 150	130 x 150	130 x 75
Sleeve holder		MK 2	MK 2	MK 2	
Travel of movable centre	mm	20	20	20	
Contact area in V-block	mm	d = 10 - 50			d = 25 - 150
Accuracy centres height	mm	±0.01	±0.01	±0.01	±0.02
Standard		•			
Hand wheel			•		
Pneumatic				•	
Run-out accuracy	mm				0.003
Weight/pair	kg	ca. 30	ca. 31	ca. 31	ca. 15

P = with V-block RH = with hand wheel RP = with pneumatic cylinder

Vertical run-out testers
 Height of centres 50 mm
 Height of centres 75 mm
 Height of centres 100 mm

RPV 50-350



The picture shows the RPV 50-350 vertical run-out tester equipped with 2 THL-50 probe holders. (not within scope of delivery)

Other centre distances on request.

Model		RPV 50-350	RPV 75-350P	RPV 100-450
maximum centre distance	mm	350	350	450
Height of centres	mm	50	75	100
Dimensions of base plate	mm	530 x 105	530 x 105	700 x 135
Flatness of base plate		DIN 876/1	DIN 876/1	DIN 876/1
T-slot width	mm	10H7	10H7	12H7
Contact area in V-block	mm		5 - 20	
Dial gauge holder	mm	8H7	8H7	8H7
Travel of movable centre	mm	8	8	8
Distance between guide slot and clamping slot	mm	58	58	67
Total height	mm	580	580	755
Weight	kg	ca. 30.5	ca. 31.5	ca. 68.0

Accessories for vertical run-out testers with
 height of centres 50 mm
 height of centres 75 mm
 height of centres 100 mm

Tailstock pairs

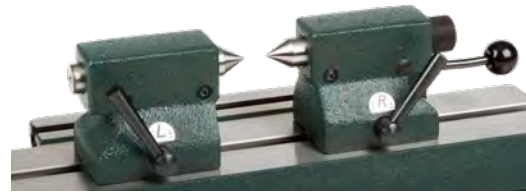

Model		RST 50	RST 75P	RST 100
Height of centres	mm	50	75	100
Width of T-slot block	mm	10h6	10h6	12h6
Contact area in V-block	mm		5 - 20	
Surface LxW	mm	66 x 55	66 x 55	85 x 80
Travel of movable centre	mm	8	8	8
Accuracy centres height	mm	±0.01	±0.01	±0.01
Weight/pair	kg	ca. 2.5	ca. 3.5	ca. 9

Centering points – hollow centres 004-56
 with centering hole DIN 332-A1, 6 x 3.8



Centering points 004-57
 60° carbide tipped
 Shank of centering points: dia. 16 mm



Standard centres 004-56S
 Standard centres, 60°

We will be glad to manufacture centering points according to your specifications.

Comparator holder











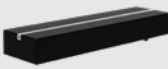

Model		THL-50	THL-100
Height of centres fixed	mm	50	100
Dial gauge holder	mm	8H7	8H7
for T-slot	mm	10H7	12H7

The probe holder allows the dial gauge to be locked in a horizontal position.

Run-out testers

Possible component combinations

Work-holding tables	Tailstocks / Roller wheels / V-blocks	Dial gauge stands	Accessories
<p>AT 200 AT 350 AT 500</p> 	<p>RST 50 RST 75P RST 75D-10</p> <p>AB 004-54 AB 004-64</p> <p>PB 004-53 PB 004-63 HV</p> 	<p>MS 004-55 MS 004-55S</p>	<p>Pressure Wheel AR 004-51 Comparator holder THL 50 V-block inserts PE 004-52</p> <p>Centering points: ZS 004-56 (Hollow centres) ZS 004-57 (Carbide) ZS 004-56 S (Standard)</p> <p>For AB 004-54: End stop AS 004-53 Dial gauge holder MU 004-53</p>
<p>AT 700</p> 	<p>RST 100 RST 100 P</p> <p>RST 150 RST 150 P</p> <p>RST 100 RH RST 100 RP</p> <p>RST 150 RH RST 150 RP RST 100 D</p> <p>RST 100 D-16</p> <p>RST 150 D</p> <p>AB 002-104 AB 002-114</p> <p>PB 002-103 PB 002-113 HV</p> 	<p>MS 002-105 MS 002-105-450</p>	<p>Comparator holder THL 100 V-block inserts PE 002-102</p> <p>Centering points: ZS 002-106 (Hollow centres) ZS 002-107 (Carbide) ZS 002-106 M (mitlaufend) ZS 002-106 S (Standard)</p> <p>For AB 002-104: End stop AS 002-103 Dial gauge holder MU 002-103</p>
<p>AT 1100 HG (other length on request)</p> 	<p>RST 200 /RST 200 P RST 200 RH / RST 200 RP</p> <p>AB 200</p> 	<p>MS 200</p>	
<p>AT 530 V (vertikal)</p> 	<p>RST 50 RST 75P</p> 	<p>MS 004-55 MS 004-55S</p>	<p>Comparator holder THL 50</p>
<p>AT 700 V (vertikal)</p> 	<p>RST 100 RST 150</p> 	<p>MS 002-105 MS 002-105-450</p>	<p>Comparator holder THL 100</p>

P = with V-block RH = with hand wheel RP = with pneumatic cylinder

Dial gauges are not included.

Run-out testers

Overview of components

Work-holding tables

	AT 200	AT 350	AT 500	AT 530V	AT 700	AT 700V	AT 1100 HG
Length in mm	200	350	500	530	700	700	1100
Groove width	10H7	10H7	10H7	10H7	12H7	12H7	14H7
Groove width of stand	10 ±0.01	10 ±0.01	10 ±0.01	10 ±0.01	12 ±0.01	12 ±0.01	
Precision as per DIN 876	1	1	1	1	1	1	0
Vertical with standing plate				•		•	

Tail stocks

		RST 50	RST 75 P	RST 100	RST 100 P	RST 100 RH	RST 100 RP	RST 150	RST 150 P	RST 150 RH	RST 150 RP	RST 200	RST 200 P	RST 200 RH	RST 200 RP
Height of centres	mm	50	75	100	100	100	100	150	150	150	150	200	200	200	200
Width of T-slot	mm	10h6	10h6	12h6	12h6	12h6	12h6	12h6	12h6	12h6	12h6	14h6	14h6	14h6	14h6
Contact area in V-block	mm		5 - 20		8 - 32			8 - 32					10 - 50		
Surface LxW	mm	66 x 55	66 x 55	85 x 80	85 x 80	85 x 80	85 x 80	95 x 85	95 x 85	95 x 85	95 x 85	130 x 150	130 x 150	130 x 150	130 x 150
Travel of movable center	mm	8	8	8	8	20	20	8	8	20	20	20	20	20	20
Accuracy centres height	mm	±0.01	±0.01	±0.01	±0.01	±0.01	±0.01	±0.01	±0.01	±0.01	±0.01	±0.01	±0.01	±0.01	±0.01
Standard		•	•	•	•			•	•			•	•		
Handwheel						•				•				•	
Pneumatic-cylinder							•				•				•
Weight/pair	kg	ca. 2.5	ca. 3.5	ca. 9	ca. 9	ca. 9	ca. 9	ca. 12	ca. 12	ca. 12	ca. 12	ca. 28	ca. 30	ca. 31	ca. 31

Roller wheels / V-blocks

		AB 004-54	AB 004-64	AB 002-104	AB 002-114	AB 200	PB 004-53	PB 004-63HV	PB 002-103	PB 002-113HV
Vertically adjustable			•		•			•		•
Height of centres at d = 10mm	mm	56	66	91.5	99			66.5	93	103
Height of centres at d = 25mm						147				
Width of T-slot block	mm	10h6	10h6	12h6	12h6	14h6	10h6	10h6	12h6	12h6
Wheel width	mm	8	8	8	8	15				
V-block width							10	10	10	10
Contact area in V-block	mm	d = 2 - 40	d = 2 - 32	d = 2 - 60	d = 2 - 65	d = 25 - 150	d = 5 - 25	d = 5 - 25	d = 8 - 50	d = 8-50
Minimum spacing	mm	22	16	32	22	70	20	20	30	30
Weight/pair	kg	ca. 1.0	ca. 1.8	ca. 4.0	ca. 4.0	ca. 15.0	ca. 1.0	ca. 2.0	ca. 4.0	ca. 5.5

Dial gauge stands

		MS 004-55	MS 004-55S	MS 002-105	MS 002-105-450	MS 200
Height	mm	220	220	240	440	420
Measuring range	mm	180	180	230	430	365
Reach	mm	100	60	130	130	180
Column dia.	mm	16	16	22	22	35
Dial gauge holder	mm	8h7	8h7	8h7	8h7	8h7
Fine adjustment			•		•	•
Horizontal measuring arm with rotation lock						opt.
Weight	kg	0.9	0.9	1.5	2.0	7.0

Load and run-out accuracy

Maximum load of Benzing roller wheels

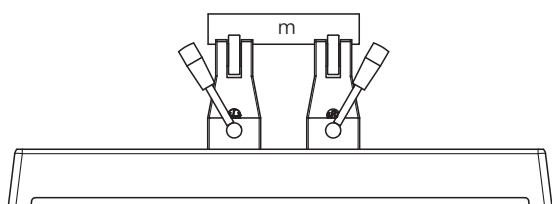

		m / Roller wheel pair
AB 004	kg	20
AB 002	kg	30
AB 200	kg	150

Maximum load of tailstocks

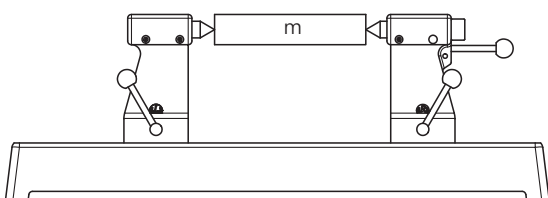

The values given are based on centring holes DIN 332-A, 1.5 x 3.35

		m / Tailstock pair
RST 50	kg	10
RST 75	kg	10
RST 100	kg	20
RST 150	kg	20
RST 200	kg	40

Run-out accuracy of Benzing roller wheels

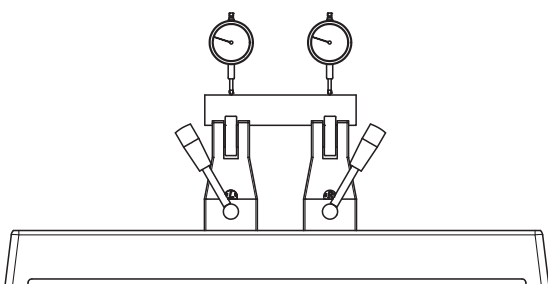

		max. deviation
AB 004	mm	0.003
AB 002	mm	0.003
AB 200	mm	0.003

Dial gauges and collets



B02A
B02A-S

	B02A	B02A-S
Scale graduation	0.01 mm	0.01 mm
Measuring range	10 mm	10 mm
1 pointer revolution	1 mm	1 mm
Outer ring diameter	58 mm	58 mm
Clamping shaft diameter	8h6	8h6
Design features	DIN EN ISO 463/DIN 878	DIN EN ISO 463/DIN 878
Shock protection		•
Initial measuring force	0.7 N ± 10%	0.7 N ± 10%



	F10		F14		F20	
Internal diameter	0.5 - 8.0		1.0 - 10.0		0.5 - 17.0	
Graduation	∅ 0.5 - 0.9	0.1	∅ 1.0 - 8.0	0.5	∅ 0.5 - 0.9	0.1
	∅ 1.0 - 8.0	0.5	∅ 9.0 - 10.0	1	∅ 1.5 - 17.0	0.5
fits	RP 006		RST 75D-10 RP 001-75D-10 RST 100 D		RST 100 D-16	

Run-out accuracy tolerances of collets.

The run-out accuracy is measured using a measuring pin at a distance L from the collet.

Holes from	t ₀	L	Standard collet μm	Ultra-precision collet μm
0.5	1.0	3	10	5
1.1	1.6	6	10	5
1.7	3.0	10	15	8
3.1	6.0	16	15	8
6.1	10.0	25	15	8
10.1	16.0	40	20	10

Run-out tester with rotating collet
Run-out tester with collet attachment

RP 001-75D-10



The MFH measuring probe holder can be inserted into the dial gauge holder of the RP 001-75D-10 run-out tester for measuring interior diameters.

RP 006



RP 006 run-out tester with F10 collet attachment and sliding 8H7 dial gauge holder.

The collet attachment does not rotate.

Collets are not included.



Matching collets can be found on page 19.

Model		RP 001-75D-10	RP 006
Height of centres	mm	75	
Dimensions of base plate	mm	200 x 110	
Flatness of base plate		DIN 876/1	
T-slot width	mm	10H7	
Dial gauge holder	mm	8H7	8H7
Collet type		F 14	F 10
for collet range	mm	0.5 - 10	0.5 - 7
Run-out accuracy without collet	µm	5	
Weight	kg	5.6	1.8

The tolerance of the collet must be added to the stated run-out accuracy of the tailstock. See the table on page 19 for details.

Run-out testing and straightening.

BENZING hand lever presses are ideal for reworking your parts.
Ask for our press brochure or download it at www.horst-benzing.de.

Ideal for parts up to 10 mm dia. Please note that the required straightening force also depends on the length of the workpiece.

Manual toggle press with fixture for straightening



Measuring probe TRT 200



Straightening punch RSt-H



Straightening blocks RB 1/200 equipped with straightening plates RP 1-W

Straightening plates must be ordered separately.



Straightening blocks and straightening plates are supplied only in pairs.

Straightening table RT 1/200



Pair of straightening plates RP 1-W



Model			RT 1/200	RB 1/200	RP 1-W	RSt-H	Model		TRT 200
Dimensions	AxB	mm	400 x 80	55 x 25			Dial gauge holder	mm	8H7
Height		mm	60	60			Measuring range	mm	5
Size of straightening block		mm		35 x 30 x 10	35 x 30 x 10				
T-slot		mm	10	10					
Spigot		mm				10h8			
Weight		kg	ca. 7.5	ca. 1			Weight	kg	ca. 0.5

Taper measuring instrument

Height of centres 50 mm

height of centres 75 mm

The taper measuring instrument KMG-1 consists of a movable slide mounted without play on precision ball guides and an inclinable sine bar. The slide can be locked in any position on the x-axis.

Measurements with the KMG-1 are based on the sine bar principle. The setting height *S* for the sine table is calculated as follows:

$$\text{Setting height } S = 320 \text{ mm} \times \sin \alpha$$

A gauge block is placed on the sine table of the device to set the calculated setting height *S*.

The dial gauge should have a flat probe to find the highest point of the cone being measured.

Tailstocks are not included and must be ordered separately.

Taper measuring instrument with Tailstock pair RST 50

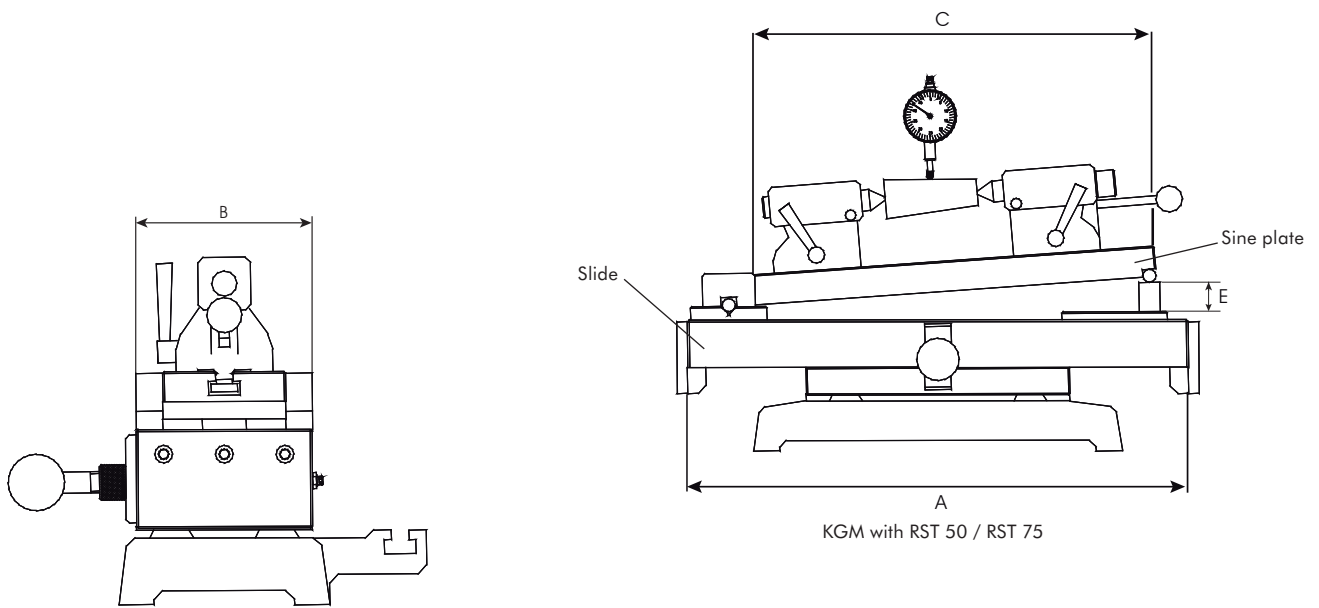

Model			KMG-1
maximum centre distance with RST 50		mm	200
with RST 75		mm	200
Table dimensions	AxB	mm	400 x 100
Height of table		mm	85
Table travel		mm	150
Sine table dimensions	CxD	mm	330 x 70
Flatness of sine table			DIN 876/1
T-slot width		mm	10H7
Dial gauge holder		mm	8H7
Height with stand		mm	260
Weight		kg	ca. 24

Accessories for taper measuring device with height of centres 50 mm height of centres 75 mm

Centering points – hollow centres 004-56
with centering hole DIN 332-A1.6 x 3.8



Centering points 004-57
60° carbide tipped
Shank of centering points: dia. 16 mm



Centering points 004-56S
Standard centering points, 60°

We will be glad to manufacture centering points according to your specifications.

Tailstock pairs



RST 50

RST 75 P

Model		RST 50	RST 75 P
Height of centres	mm	50	75
Width of T-slot block	mm	10h6	10h6
Contact area in V-block	mm		5 - 20
Surface LxW	mm	66 x 55	66 x 55
Travel distance of movable centre	mm	8	8
Accuracy centres height	mm	±0.01	±0.01
Weight/pair	kg	ca. 2.5	ca. 3.5

Comparator stands with round table

MT 25
MT 50

MT 25



MT 50



MT 50 K



MT 50 bK



MT 50b HG



The table surfaces of models MT 25 and MT 50 are lapped. The table of MT 50 K is made of high-quality Al₂O₃ 99.7% ceramic and is also lapped.

The columns of all models are made of hardened and precision-ground steel.

The measuring frame of MT 25 can be inclined to an optimal working position.

Measuring inserts for MT 25:

MT 25-A: Measuring table plate dia. 5 mm

MT 25-B: Measuring table plate dia. 8 mm

MT 50 F



Model with fine adjustment of dial gauge height. Adjustment range 15 mm.

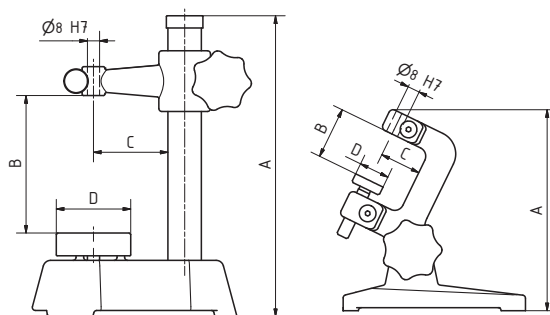

Horizontal measuring frame MB 22



Frame fits to all versions of MT 50 and MT 100.

It can be used for run-out tests and for measurements of grooves and recesses on cylinders.

Horizontal measuring frame		MB 22
Reach of measuring frame	mm	40
Size of gap	mm	60
Fits column diameter	mm	22
Dial gauge holder	mm	8H7
Weight	kg	ca. 0.5

Model		MT 25	MT 50	MT 50 b	MT 50 K	MT 50 bK	MT 50 F	MT 50 KF	MT 50 HG	MT 50b HG
Total height	A mm	150	200	105	200	105	200	200	200	200
Measuring range – vertical	B mm	40	105	105	105	105	105	105	105	105
Reach	C mm	27	49	90	49	90	49	49	49	90
Measuring table dia.	D mm	20	50	50	50	50	50	50	50	50
Flatness	μm	4,08	4,4	4,4	≤ 2	≤ 2	4,4	≤ 2	DIN 876/0	DIN 876/0
Column diameter	mm		22	22	22	22	22	22	22	22
Dial gauge holder	mm	8H7	8H7	8H7	8H7	8H7	8H7	8H7	8H7	8H7
Measuring table material		Steel	Steel	Steel	Ceramic	Ceramic	Steel	Ceramic	Granite	Granite
Weight	kg	ca. 1.2	ca. 2.3	ca. 2.5	ca. 2.3	ca. 2.5	ca. 2.5	ca. 2.5	ca. 2.3	ca. 2.5
Extras										
Horizontal measuring frame MB 22			•	•	•	•	•	•	•	•

Comparator stands with a rectangular table MT 100

The table surfaces of models MT 100 and MT 100 b are lapped.

The tables of MT 100 K and MT 100 bK are made of high-quality Al₂O₃ 99.7% ceramic and are also lapped.

The columns of all models are made of hardened and precision-ground steel.

MT 100



MT 100 b



MT 100 K



MT 100 bK



MT 100 HG



MT 100b HG

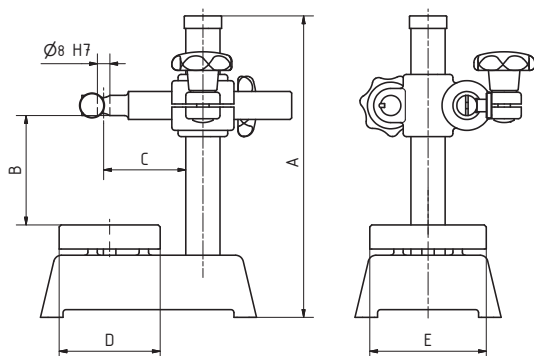

Model			MT 100	MT 100 b	MT 100 K	MT 100 bK	MT 100 HG	MT 100b HG
Total height	A	mm	200	200	200	200	200	200
Measuring range – vertical	B	mm	100	100	100	100	105	105
Measuring range – horizontal	C	mm	49	90	49	90	49	90
Measuring table area	D x E	mm	60 x 68	60 x 68	65 x 75	65 x 75	65 x 75	65 x 75
Column diameter		mm	22	22	22	22	22	22
Dial gauge holder		mm	8H7	8H7	8H7	8H7	8H7	8H7
Measuring table material			Steel	Steel	Ceramic	Ceramic	Granite	Granite
Flatness		µm	4.27	4.27	≤ 2	≤ 2	DIN 876/0	DIN 876/0
Dust grooves			•	•				
Weight		kg	ca. 3.2	ca. 3.5	ca. 3.2	ca. 3.5	ca. 3.2	ca. 3.5
Extras								
Measuring frame MB22			•	•	•	•	•	•

Comparator stands with rectangular table MT 130

The table surfaces of models MT 130 and MT 130 b are lapped.

The tables of models MT 130 K and MT 130 bK are made of high-quality lapped Al_2O_3 99.7% ceramic.

The columns of all models are made of hardened and precision-ground steel.

Measuring tables MT 130 b, MT 130 bK and MT 130 b HG have interchangeable dial gauge holders.

MT 130



MT 130 b



MT 130 K



MT 130 bK



MT 130 HG



MT 130b HG

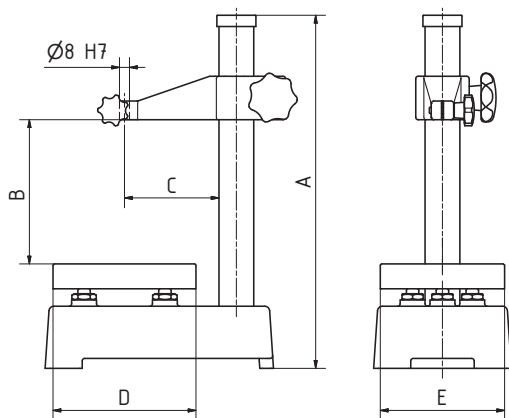

Model			MT 130	MT 130 b	MT 130 K	MT 130 bK	MT 130 HG	MT 130b HG
Total height	A	mm	284	284	284	285	284	284
Measuring range – vertical	B	mm	155	165	155	165	155	165
Measuring range – horizontal	C	mm	76	135	76	135	76	135
Measuring table area	DxE	mm	98 x 115	98 x 115	100 x 115	100 x 115	100 x 115	100 x 115
Column diameter		mm	28	28	28	28	28	28
Dial gauge holder		mm	8H7	8H7	8H7	8H7	8H7	8H7
Measuring table material			Steel	Steel	Ceramic	Ceramic	Granite	Granite
Flatness		μm	4.46	4.46	≤ 3	≤ 3	0	0
Dust grooves			•	•				
Weight		kg	ca. 7.0	ca. 7.1	ca. 7.0	ca. 7.1	ca. 7.0	ca. 7.1

MT 150-U1



MT 150-U2



MT 150-U3



The dial gauge holders of these models are interchangeable. Holders can be supplied with 20H7, 25H7, 28H7 and 30H7 holes. Adapters for commonly used electronic lengthmeasuring probes are available.

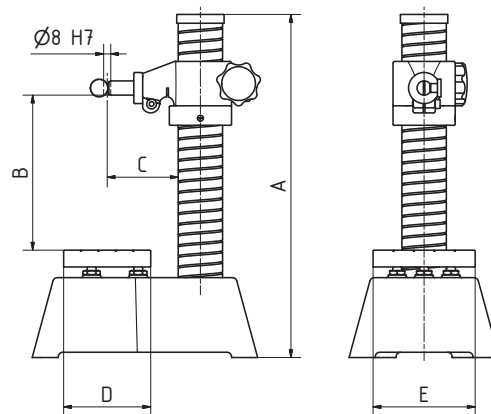

Model			MT 150 U-1	MT 150 U-2	MT 150 U-3
Total height	A	mm	390	390	390
Measuring range – vertical	B	mm	20-220	20-220	3-185
Measuring range – horizontal	C	mm	80	80	80
Measuring table area	DxE	mm	dia. 115	98 x 115	
Measuring block – V-block depth		mm			10 / 90°
Measuring block – measuring table area	DxE	mm			48 x 100
Column diameter		mm	50	50	50
Dial gauge holder		mm	8H7	8H7	8H7
Measuring table material			Steel	Steel	Steel
Flatness		µm	4.46	4.46	4.32
Dust grooves			•	•	•
Weight		kg	ca. 20.0	ca. 20.0	ca. 20.0

Extra-sturdy comparator stands MT 160

**MT 160 SOGG
MT 160 SOGL**



**MT 160 SMGG
MT 160 SMGL**



**MT 160 SOGGG
MT 160 SOGGL**



The comparator stands in the MT 160 series are distinguished by a large measurement surface. They were designed for high accuracy in spite of their rugged construction.

The measuring table plate rests on an adjustable three-point support.

Types MT 160b and MT 160 U-50b have a sliding horizontal measuring arm that can reach every point of the measurement surface.

The horizontal measuring arm of types MT 160b and MT 160 U-50b can also be supplied with a rotation lock for special requirements.

Model			MT 160 SOGG	MT 160 SOGL	MT 160 SMGG	MT 160 SMGL	MT 160 SOGGG	MT 160 SOGGL
Total height	A	mm	320	320	320	320	390	390
Measuring range – vertical	B	mm	165	165	165	165	155	155
Reach	C	mm	104	104	104	104	104	104
Measuring table area	D x E	mm	170 x 215	170 x 215	170 x 215	170 x 215	170 x 215	170 x 215
Precision-ground table surface			•		•		•	
Lapped table surface				•		•		•
Column diameter		mm	35	35	35	35	35	35
Smooth column			•	•				
Column with thread and setting ring					•	•		
Column with hand wheel for vertical adjustment							•	•
Dial gauge holder		mm	8H7	8H7	8H7	8H7	8H7	8H7
Measuring table material			Steel	Steel	Steel	Steel	Steel	Steel
Flatness		µm	16.00	4.86	16.00	4.86	16.00	4.86
Dust grooves			•	•	•	•	•	•
Weight		kg	ca. 22	ca. 22	ca. 22	ca. 22	ca. 22	ca. 22

MT 160b SOGG MT 160b SOGL



MT 160b SMGG MT 160b SMGL MT 160U 50b-GS MT 160U 50b-GL MT 160U 50b-GSV MT 160U 50b-GLV



The dial gauge holders of the MT 160b types are interchangeable. Holders are available with 20H7, 25H7, 28H7 and 30H7 holes. Adapters for commonly used electronic lengthmeasuring probes are available.

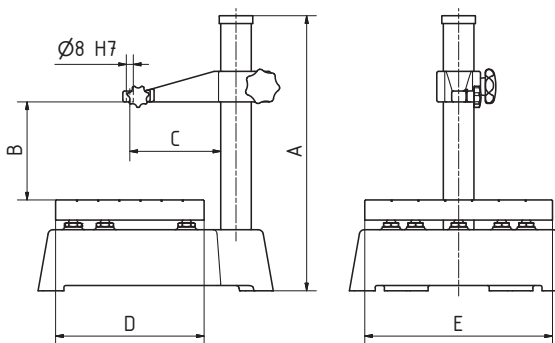

Model			MT 160 b SOGG	MT 160 b SOGL	MT 160 b SMGG	MT 160 b SMGL	MT 160 U 50b-GS	MT 160 U 50b-GL	MT 160 U 50b-GSV	MT 160 U 50b-GLV
Total height	A	mm	320	320	320	320	370	370	370	370
Measuring range – vertical	B	mm	175	175	175	175	215	215	215	215
Reach up to	C	mm	180	180	180	180	220	220	220	220
Measuring table area	D x E	mm	170 x 215	170 x 215	170 x 215	170 x 215	170 x 215	170 x 215	170 x 215	170 x 215
Precision-ground table surface			•		•		•		•	
Lapped table surface				•		•		•		•
Column diameter		mm	35	35	35	35	50	50	50	50
Smooth column			•	•						
Column with thread and setting ring					•	•	•	•	•	•
Horizontal measuring arm with rotation lock (o=option)			o	o	o	o	o	o	•	•
Dial gauge holder		mm	8H7	8H7	8H7	8H7	8H7	8H7	8H7	8H7
Interchangeable dial gauge holder			•	•	•	•	•	•	•	•
Measuring table material			Steel	Steel	Steel	Steel	Steel	Steel	Steel	Steel
Flatness		µm	16.00	4.86	16.00	4.86	16.00	4.86	16.00	4.86
Dust grooves			•	•	•	•	•	•	•	•
Weight		kg	ca. 22	ca. 22	ca. 22	ca. 22	ca. 26	ca. 26	ca. 26	ca. 26

Comparator stands with long reach MT 180

**MT 180-1
MT 180-2**



**MT 180-G1
MT 180-G2**



**MT 180-1H
MT 180-2H**



The measuring tables in the MT 180 series are distinguished by their long reach, sturdy column and large measurement surface. Another advantage is their low weight.

The measuring table plate rests on an adjustable three-point support.

Model			MT 180-1	MT 180-2	MT 180-G1	MT 180-G2	MT 180-1H	MT 180-2H
Total height	A	mm	320	320	320	320	390	390
Measuring range – vertical	B	mm	170	170	170	170	160	160
Reach	C	mm	104	104	104	104	104	104
Measuring table area	D x E	mm	180 x 98	180 x 98	180 x 98	180 x 98	180 x 98	180 x 98
Precision-ground table surface			•		•		•	
Lapped table surface				•		•		•
Column diameter		mm	35	35	35	35	35	35
Smooth column			•	•				
Column with thread and setting ring					•	•		
Column with hand wheel for vertical adjustment							•	•
Dial gauge holder		mm	8H7	8H7	8H7	8H7	8H7	8H7
Interchangeable dial gauge holder								
Measuring table material			Steel	Steel	Steel	Steel	Steel	Steel
Flatness		µm	10	4.74	10	4.74	10	4.74
Dust grooves			•	•	•	•	•	•
Weight		kg	ca. 12	ca. 12	ca. 12	ca. 12	ca. 12	ca. 12

MT 180 b-1
MT 180 b-2



MT 180 b-G1
MT 180 b-G2



The MT 180b models have a sliding horizontal measuring arm that can reach every point of the measurement surface.

The horizontal measuring arm can also be equipped with a rotation lock.

The dial gauge holder is interchangeable. Mounting holes for commonly used length measuring probes are available.

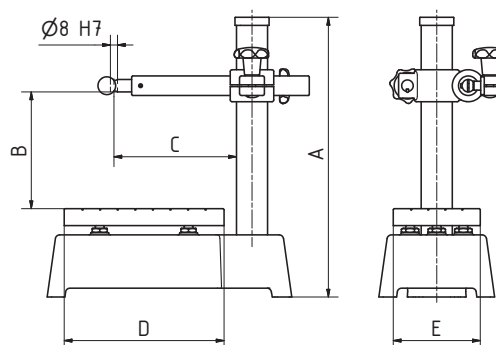

Model			MT 180 b-1	MT 180 b-2	MT 180 b-G1	MT 180 b-G2
Total height	A	mm	320	320	320	320
Measuring range – vertical	B	mm	180	180	180	180
Reach up to	C	mm	180	180	180	180
Measuring table area	D x E	mm	180 x 98	180 x 98	180 x 98	180 x 98
Precision-ground table surface			•		•	
Lapped table surface				•		•
Column diameter		mm	35	35	35	35
Smooth column			•	•		
Column with thread and setting ring					•	•
Horizontal measuring arm with rotation lock (o=option)			o	o	o	o
Dial gauge holder		mm	8H7	8H7	8H7	8H7
Interchangeable dial gauge holder			•	•	•	•
Measuring table material			Steel	Steel	Steel	Steel
Flatness		µm	10	4.74	10	4.74
Dust grooves			•	•	•	•
Weight		kg	ca. 13	ca. 13	ca. 13	ca. 13

Comparator stands with granite base plate.

MT 170 MT 171
MT 172 MT 300

These measuring tables have base plates made of natural black granite. Aged over millions of years, the rock material is tension-free, wear-proof, and harder than steel. The measurement surface is corrosion-free and non-magnetic. It requires no special care.

The surface is lapped and the flatness of the measurement surface conforms to DIN 876/00.

The columns are hard chrome-plated and ground.

In models

MT 170 b-HG

MT 171 b-HG

MT 300 b-HG

MT 300 b-HGV

the dial gauge holder is interchangeable.

Holders with 20H7, 25H7, 28H7 and 30H7 holes are available.

Adapters for commonly used electronic length measuring probes are available.

MT 170-HG



MT 170 b-HG



MT 171-HG



MT 171 b-HG



Model			MT 170-HG	MT 170 b-HG	MT 171-HG	MT 171 b-HG
Total height	A	mm	310	310	310	310
Measuring range – vertical	B	mm	200	210	200	210
Reach	C	mm	104		104	
Reach up to	C	mm		180		180
Table dimensions	D x E	mm	260 x 150	260 x 150	260 x 150	260 x 150
Measurement surface	F x G	mm	200 x 150	200 x 150	200 x 150	200 x 150
Column diameter		mm	35	35	35	35
Smooth column			•	•		
Column with thread and setting ring					•	•
Column with hand wheel for vertical adjustment						
Horizontal measuring arm with rotation lock (o=option)				o		o
Dial gauge holder		mm	8H7	8H7	8H7	8H7
Interchangeable dial gauge holder				•		•
Measuring table material			Granite	Granite	Granite	Granite
Flatness of measurement surface as per DIN 876			00	00	00	00
Weight		kg	ca. 8.5	ca. 9.0	ca. 8.8	ca. 9.5

Comparator stands with a granite base plate

MT 170 MT 171
 MT 172 MT 300

MT 172-HG

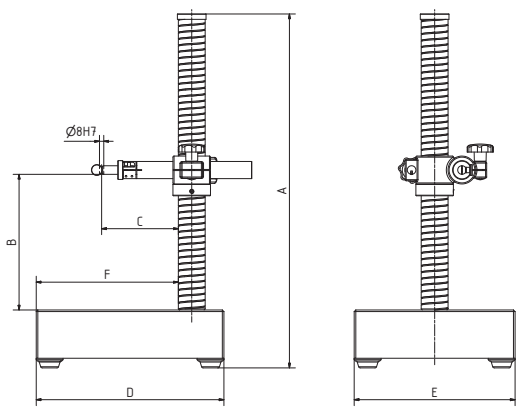

MT 300 b-HG MT 300 b-HGV

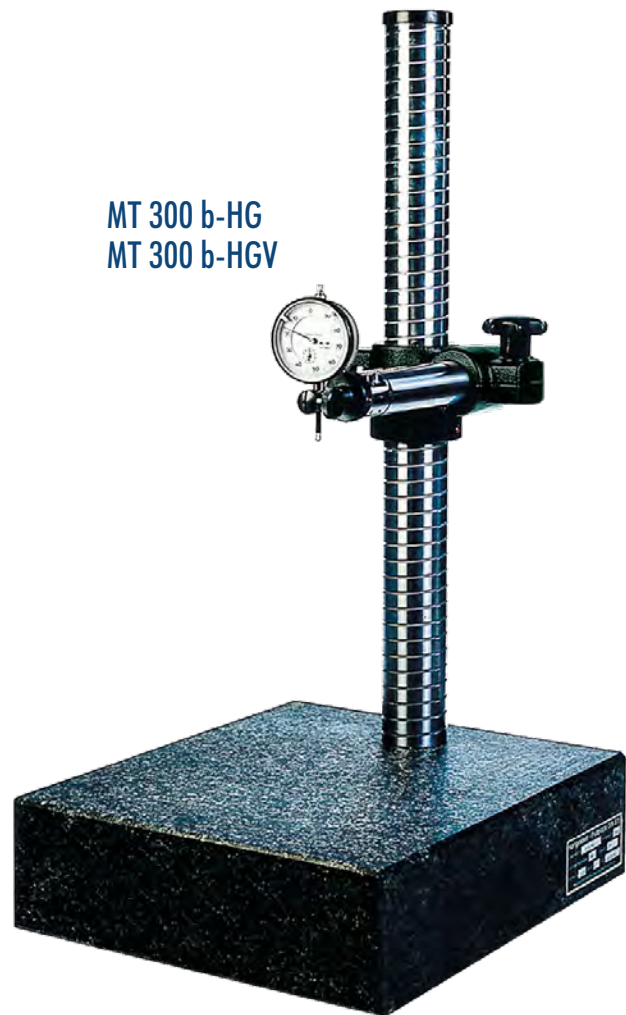

Model			MT 172-HG	MT 300 b-HG	MT 300 b-HGV
Total height	A	mm	380	660	660
Measuring range – vertical	B	mm	190	500	500
Reach	C	mm	104		
Reach up to	C	mm		220	220
Table dimensions	D x E	mm	260 x 150	350 x 300	350 x 300
Measurement surface	F x G	mm	200 x 150	260 x 300	260 x 300
Column diameter		mm	35	50	50
Smooth column					
Column with thread and setting ring				•	•
Column with hand wheel for vertical adjustment			•		
Horizontal measuring arm with rotation lock (o=option)					•
Dial gauge holder		mm	8H7	8H7	8H7
Interchangeable dial gauge holder				•	•
Measuring table material			Granite	Granite	Granite
Flatness of measurement surface as per DIN 876			00	00	00
Weight		kg	ca. 8.8	ca. 41.0	ca. 41.0

The indicator stand MS 50b is distinguished by its long reach.

It is used mainly for setting up measuring equipment. It can be attached either using a T-slot block or by bolting the flange directly onto the base plate.

The dial gauge holders are interchangeable. Holders can be supplied with 20H7, 25H7, 28H7 and 30H7 holes. Adapters for commonly used length measuring probes are available.

The horizontal measuring arm can also be supplied with a rotation lock.

The columns and the adjustable horizontal measuring arm of the models MS 50b are hard chrome plated.

MS 50b



MS 300b-HG



Model		MS 50b	MS 50b-V	MS 170-HG	MS 170b-HG	MS 171-HG	MS 171b-HG	MS 172-HG	MS 300b-HG
Total height	mm	400	400	245	245	245	245	320	550
Measuring range – vertical	mm	140 - 330	140 - 330	200	210	200	210	190	500
Reach	mm	220	220	104	180	104	180	104	220
Column diameter	mm	50	50	35	35	35	35	35	50
Dial gauge holder	mm	8H7	8H7	8H7	8H7	8H7	8H7	8H7	8H7
Interchangeable dial gauge holder		•	•		•		•		•
Rotation lock for horizontal measuring arm (o = optional)			•		o		o		o
Flange dia.	mm	115	115						
Weight	kg	ca. 11.5	ca. 11.5	ca. 2.5	ca. 3.1	ca. 2.7	ca. 3.1	ca. 3.2	ca. 12.0

Dial gauges are not included.

The bottom faces of the type MS 170 to MS 172 dial gauge stands are surface-ground and have an M 10 thread for mounting. The stands are therefore easy to mount on measuring plates, measuring equipment and granite base plates.

MS 170-HG



MS 171-HG



Model MS 171b-HG

The dial gauge holder is interchangeable. The horizontal measuring arm can also be supplied with a rotation lock.

MS 171b-HG



Model MS 172-HG

The working height of the measuring arm can be adjusted quickly and precisely by means of a threaded spindle with hand wheel. The measuring arm can then be fixed in its working position.

MS 172-HG



MA-P 40



MA-P 50



MA-P 55



MA ST



Model		MA-P 40	MA-P 50	MA-P 55	MA ST
Total height	mm	140		190	290
Diameter of column and cross arm	mm	8		12	16
Reach	mm	95	44	180	170
Magnet area	mm	dia. 40	dia. 40	dia. 52	46 x 70
Magnet strength	N	60	130	120	250
Dial gauge holder	mm	8H7	8H7	8H7	8H7
Fine adjustment of dial gauge arm				•	•
Weight	kg	ca. 0.6	ca. 0.2	ca. 1.0	ca. 2.3

Comparator stands with sectional base Swivel heads for dial gauge stands

UM-300



Swivel heads for dial gauge stands



The GK swivel head turns by 360° on all axes, allowing one to make stands, linkage mountings and other devices.

Hole diameters are provided in pairs as standard. However, it is also possible to combine holes of different diameters.

MSV 250



V-block in base 120°

Model		UM 300	MSV 250	GK 12	GK 16	GK 18
Measuring height	mm	300	260			
Diameter of column and cross arm	mm	22 / 16	16			
Hole dia.	mm			12H7 x 12H7	16H7 x 16H7	18H7 x 18H7
Reach	mm	130	140			
Dimensions of base	mm	60 x 55 x 250	40 x 65 x 140			
Dial gauge holder	mm	8H7	8H7			
Fine adjustment of dial gauge arm		•	•			
Weight	kg	ca. 5.5	ca. 3.0	ca. 0.25	ca. 0.25	ca. 0.25

Depth gauges are used for measuring the depth of grooves and holes and for checking whether surfaces, ridges, etc. are parallel.

Benzing measuring bridges for depth gauges are available in black-finished or matte chrome-plated versions and in various lengths.

We can also manufacture measuring bridges according to your specifications.

TM 80



Dial gauges are not included.

Model		TM 50	TM 50 C	TM 80	TM 80 C	TM 100	TM 100 C	TM 150	TM 150 C
Dial gauge holder	mm	8H7	8H7	8H7	8H7	8H7	8H7	8H7	8H7
Contact surface	mm	16 x 50	16 x 50	16 x 80	16 x 80	16 x 100	16 x 100	20 x 150	20 x 150
Flatness as per DIN 876		0	0	0	0	0	0	0	0
black-finished	mm	•		•		•		•	
matte chrome-plated	mm		•		•		•		•
Weight	kg	ca. 0.1	ca. 0.1	ca. 0.1	ca. 0.1	ca. 0.1	ca. 0.1	ca. 0.1	ca. 0.1

Depth gauge with special dial gauge

The scope of supply includes:

- Special dial gauge
- Measuring bridge
- Carrying case

The depth gauge is black-finished and comes in a rugged carrying case. A wide range of inserts and extensions are available for special measuring tasks.

TMG 80



Model		TMG 80	TMG 80-30
Measuring range	mm	10	30
Reading accuracy	mm	0.01	0.01
Measuring force	N	1.2	1.2
Dial gauge holder	mm	8H7	8H7
Contact surface	mm	16 x 80	16 x 80
Flatness as per DIN 876		0	0
black-finished		•	•
Weight	kg	ca. 0.5	ca. 0.5

Interior lever indicator
Angle lever indicator
Wall thickness measuring device

IF



Interior sensing lever IF

The interior lever indicator IF is used to check the alignment of holes on lathes and machine tools.

The thin lever can check small holes with a depth of up to 60 mm.

WF



Angle sensing indicator

The angle lever indicator is for aligning small cylindrical or conical holes on lathes, mills and cylindrical grinding machines.

WM



Wall thickness measuring instrument

The wall thickness measuring device can make quick and precise measurements of pipe walls.

Model		IF	WF	WM
Measuring depth	mm	60	30	
Measuring range	mm			10
smallest measurable hole dia.	mm	6	6	
Reach	mm			50
Dial gauge holder	mm	8H7	8H7	8H7
Spigot dia.	mm	8h6	8h6	
Measuring pin dia.	mm			6 / 8 / R1
Weight	kg	ca. 0.2	ca. 0.2	ca. 0.4



BENZING ist eine Marke
der mäder pressen GmbH
BENZING is a brand name
of mäder pressen GmbH



mäder pressen GmbH
Dept.: BENZING products
Robert-Bosch-Str. 13
78579 Neuhausen ob Eck
Germany

Tel: +49 - 7467 - 946 77 - 0
Fax: +49 - 7467 - 946 77 - 70

info@maederpressen.de
www.horst-benzing.de